

The Pipelined EMP CPU State Diagram for Eight MIPS Integer Instructions

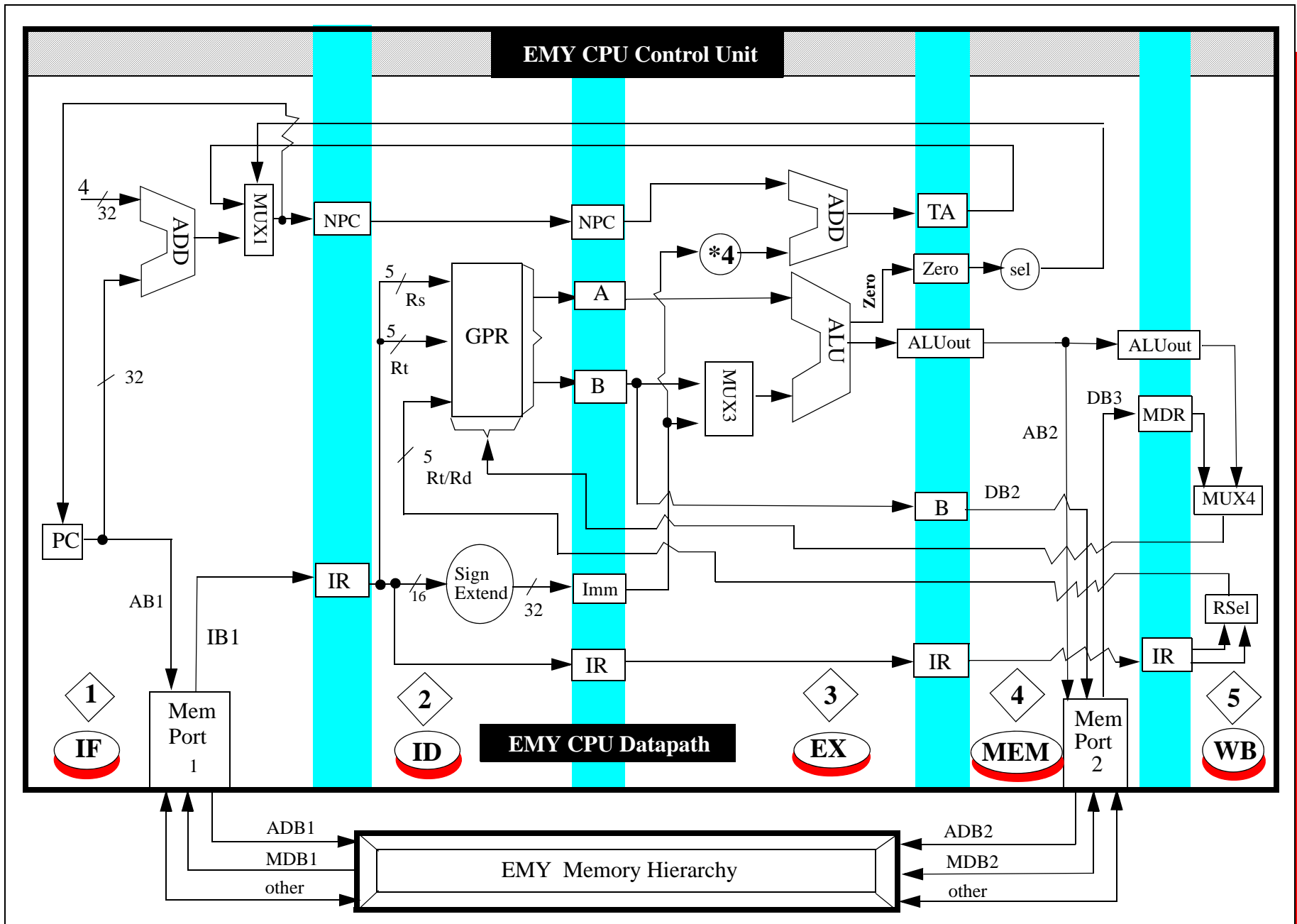

The Pipelined EMY CPU Datapath for Eight MIPS Integer Instructions